

Power unit V-ECOSILENT

New!



V-ECOSILENT – The Power Unit, which removes extra noise and stress from the demanding RTC scene by ensuring the unit remains on “tick-over”, until your rescue tool is required. Engine revs are automatically increased when the tool control button is pressed, giving the operator “revs on demand”. This Power Unit operates 2 tools simultaneously or one tool in “fast” turbo mode. Fully enclosed, this unit is a super quiet and weighing a mere 24.9kgs and measuring 580 x 295 x 445 mm is easy to carry around the scene.

Turbo

63,9 dB (A)

24,9 kg



Experience expert knowledge.

Power unit
V-ECOSILENT

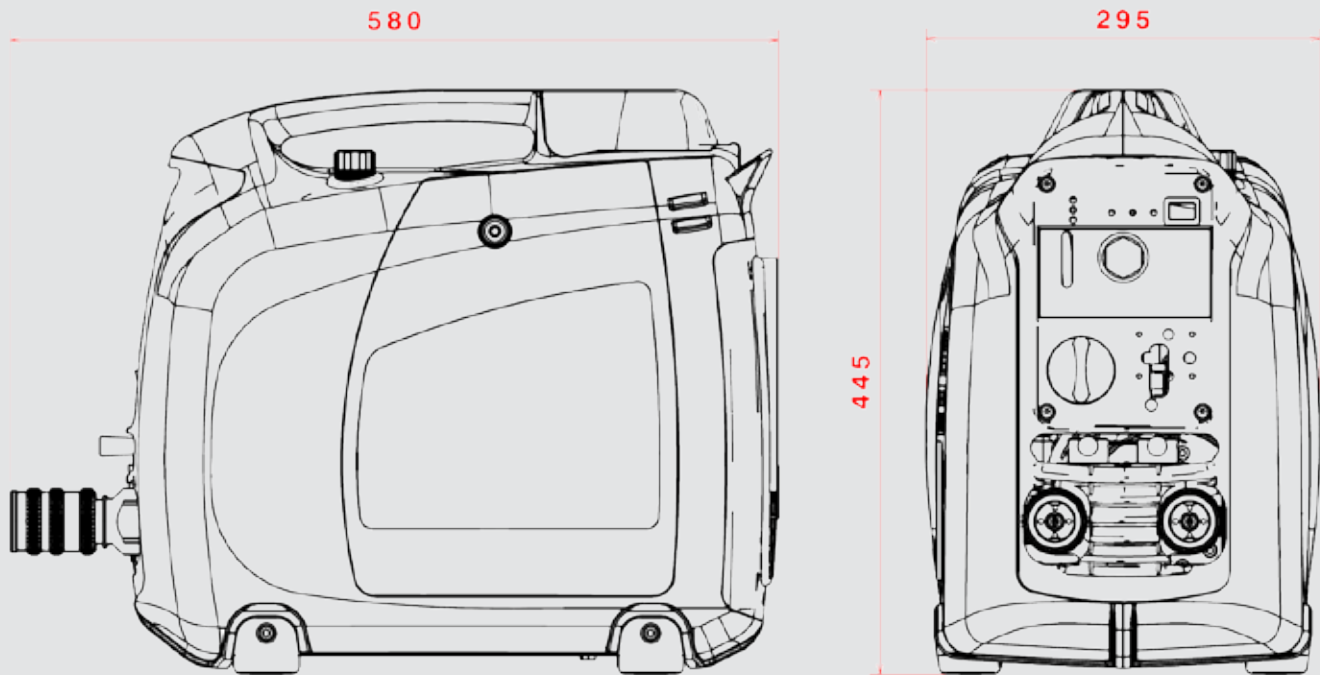

Sound level at 1m distance: min. ... 63,9 dB (A)
 max. ... 79,6 dB (A)

Motor	4 stroke gasoline engine 2,2 kW
Working pressure	630 bar / 700 bar
Oil volume	2,7 l
Weight	24,9 kg
EN-class	MTO/ATO
Part-Nr.	593.531.8

WEBER-HYDRAULIK GmbH

Heilbronner Straße 30
74363 Güglingen/Germany
Telephone +49 (0)7135/71-270
Fax +49 (0)7135/71-396
info@weber.de
www.weber-hydraulik.com

Industriegebiet 3 + 4
4460 Losenstein/Austria
Telephone +43 (0)7255/6237-0
Fax +43 (0)7255/6237461
office@weber-hydraulik.at
www.weber-hydraulik.at



Experience expert knowledge.