

TECHN. DATEN (TECHNICAL DATA):

NENNDRUCK (NOMINAL PRESSURE) P_N 70 MPa (700bar)
 PRÜFDRUCK (TEST PRESSURE) P_p 84 MPa (840bar)
 GEWICHT (WEIGHT) 14,2 kg
 (INKL. 0,3m SCHLÄUCHE U. KUPPLUNGEN; INCL. 0,3m HOSES AND COUPLINGS)
 ÖLBEDARF (REQUIRED OIL VOLUME) 0,1 l

STEUERUNG (SAFETY FEATURES)

SICHERHEITSSCHALTUNG ENTSPRECHEND EN 13204
 (WHEN CONTROL KNOBS IN NEUTRAL POSITION,
 OIL CIRCULATES WITHOUT EXERTING PRESSURE)

Schneidklasse (CUTTING CLASS):

EN 13204 (EDITION 03/2005) BC166-H-14
 NFPA 1936 (EDITION 2005) A6/B7/C7/D8/E8

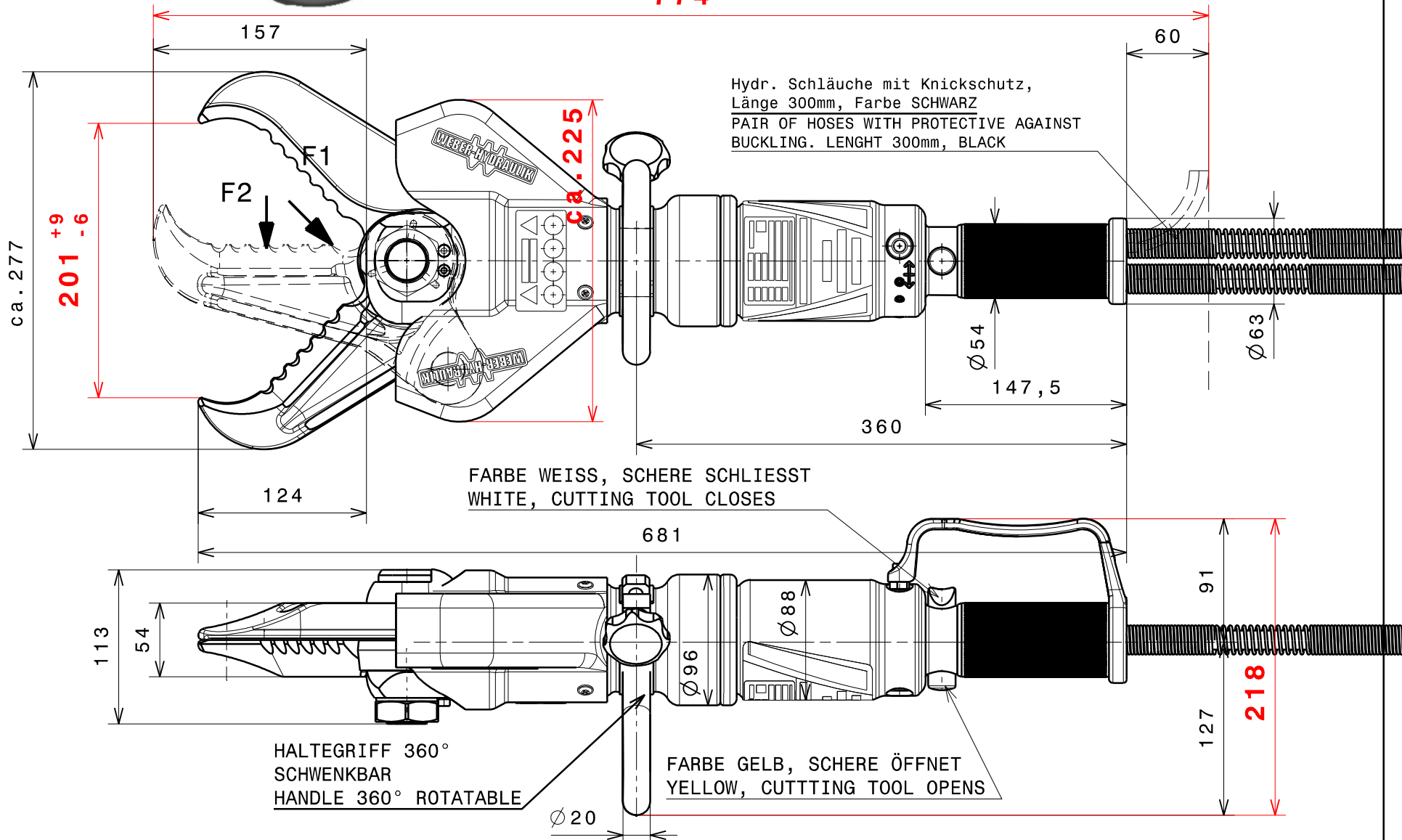
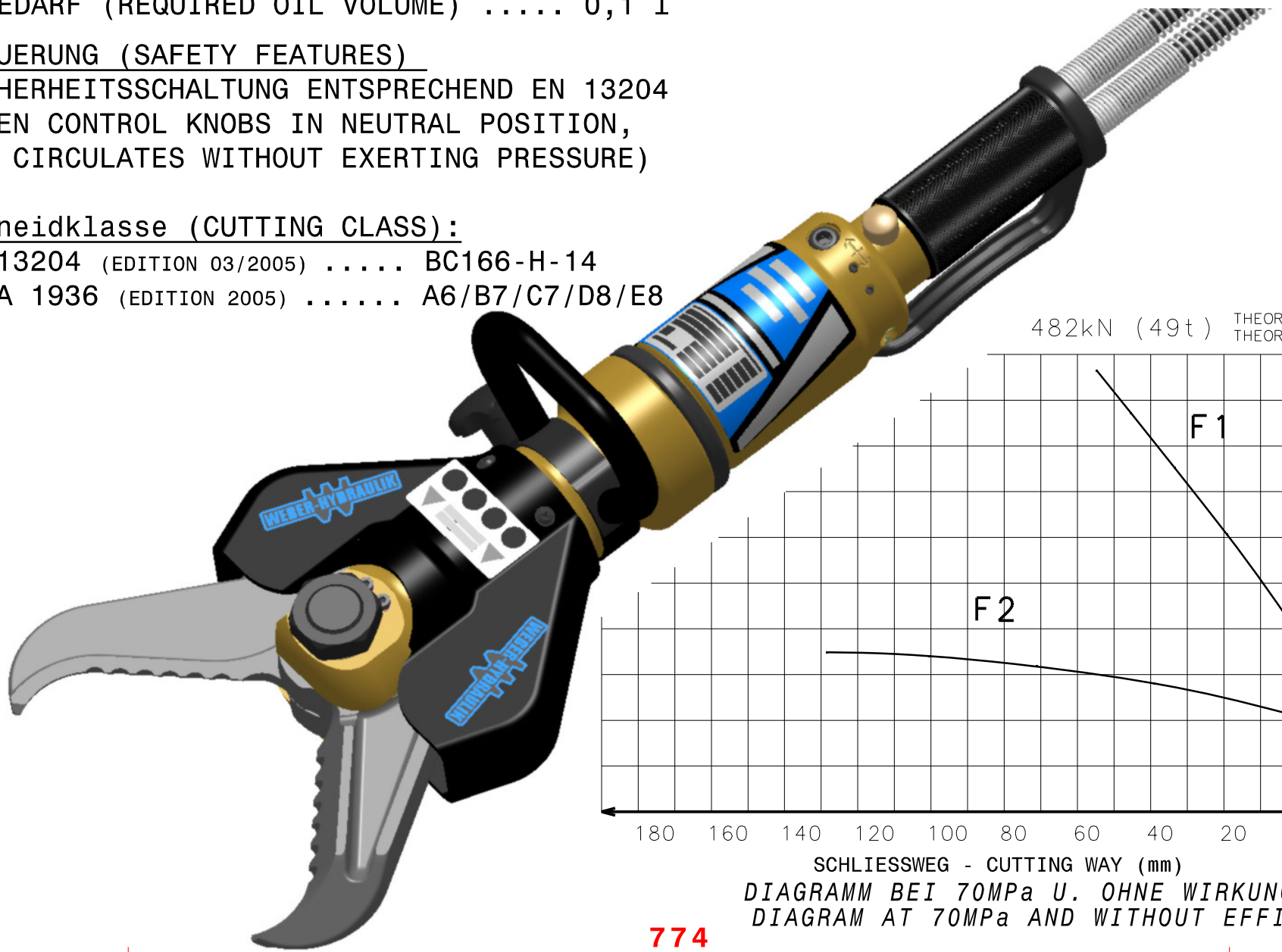

AEND.-NR.: 08036
 AEND.DATUM: 16.04.08
 GEZ.:KST
 DAT.:28.09.05
 GES.: JSC

FREIMASSTOLERANZEN (GENERAL TOLERANCES)	LAENGENMASS (LENGHT)mm	...50	50...250	250...1000	1000...	WINKELMASS (ANGLE)	...180°
	TOLERANZ (TOLERANCE)mm	±1,5	± 2,0	± 3,0	± 5,0	TOLERANZ (TOLERANCE)	±10°